

Crawler Crane

LR 1250
Litronic®

EN

LR 1004.02



LIEBHERR

Dimensions

Basic machine with undercarriage

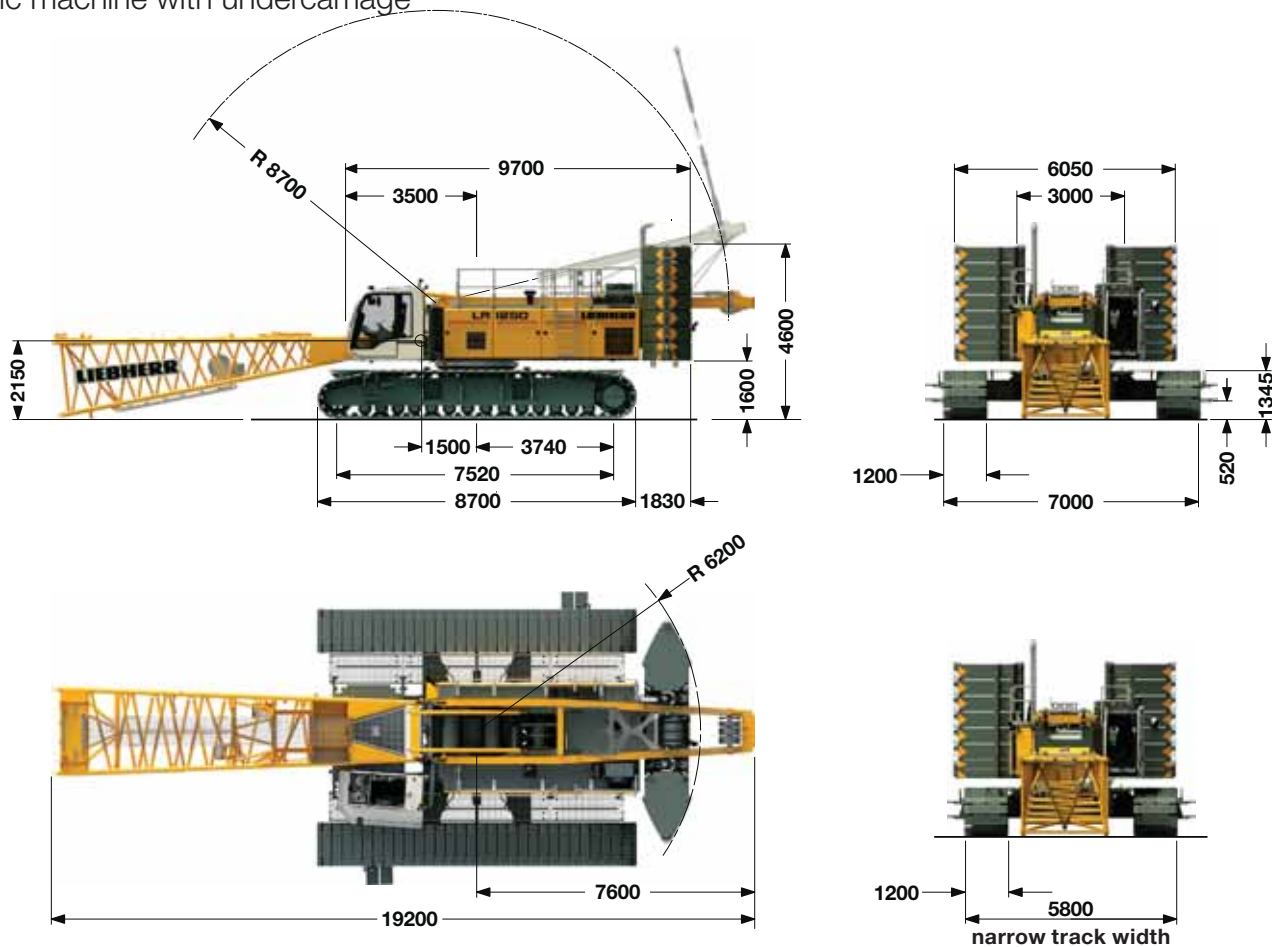

Operating weight

The operating weight includes the basic machine with crawlers, 2 main winches 120 kN including wire ropes (260 m and 495 m) and 20 m main boom, consisting of A-frame, boom foot (10 m), boom head (7 m), boom extension (3 m), 82.3 t basic counterweight, 36 t carbody counterweight and 250 t hook block.

Total weight ————— approx. 210 t

Ground pressure

The actual ground pressure is calculated according to the configuration and position of the machine and displayed in the operator's cab. Using the optional Liebherr Crane-Planner the actual ground pressure, amongst other parameters, can already be calculated and displayed in the planning stage.

Equipment

Main boom (No. 2320.xx) max. length	—————	86 m
High reach (No. 2320.xx und 1916.xx)	—————	117 m
Luffing jib (No. 1916.xx) max. length	—————	95 m
Max. combination	—————	main boom 53 m
		luffing jib 95 m
Fixed jib (No. 1008.xx)	—————	11 – 26 m
Auxiliary jib 24 t (option 36 t)		

Remarks

1. The lifting capacities stated are valid for lifting operation only (corresponding with crane classification according to F.E.M. 1.001. crane group A1).
2. Crane standing on firm, horizontal ground.
3. The weight of the lifting device (hoisting ropes, hook block, shackle etc.) must be deducted from the gross lifting capacity to obtain a net lifting value.
4. Additional equipment on boom (e.g. boom walkways, auxiliary jib) must be deducted to get the net lifting capacity.
5. For max. wind speed please refer to lift chart in operator's cab or manual.
6. Working radii are measured from center of swing and under load.
7. The lifting capacities are valid for 360 degrees of swing.
8. Calculation of stability under load is based on DIN 15019 / part 2 / chart 1 and ISO 4305 Table 1 + 2, tipping angle 4°.
9. The structures are calculated according to F.E.M. 1.001 - 1998 (EN 13001-1; EN 13001-2).

Transport dimensions and weights

Basic machine and main boom (No. 2320.xx)

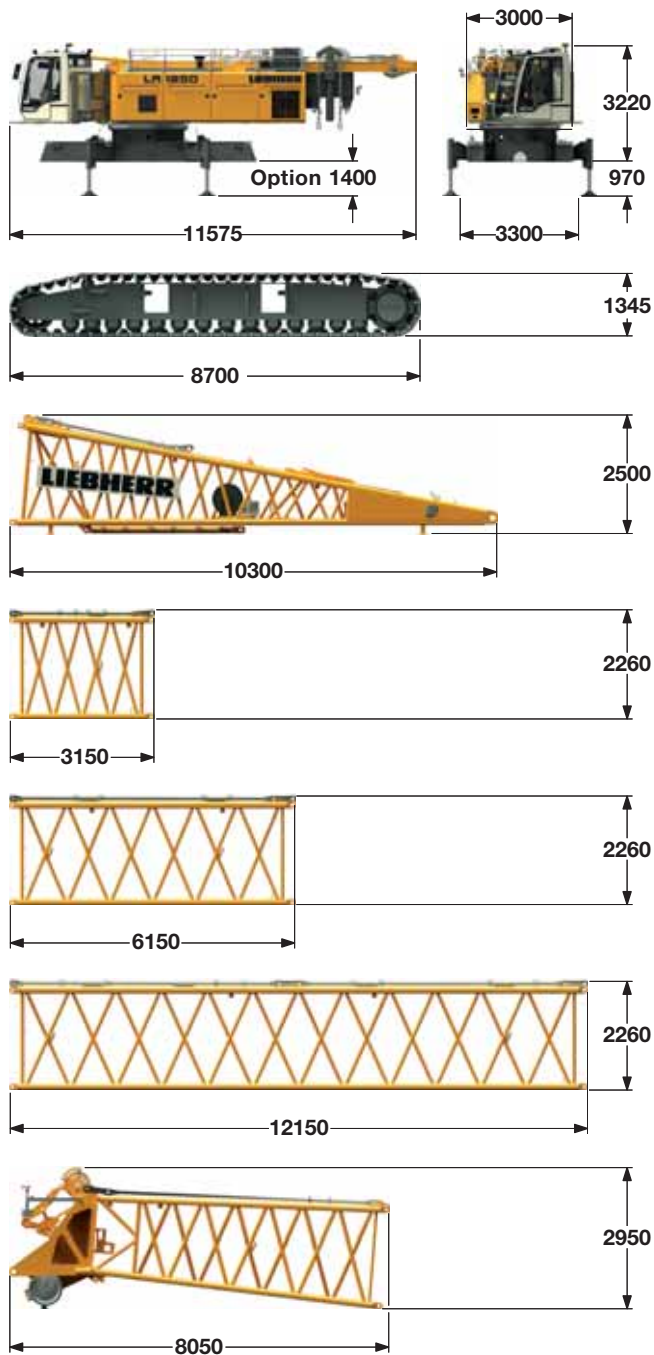

Transport option

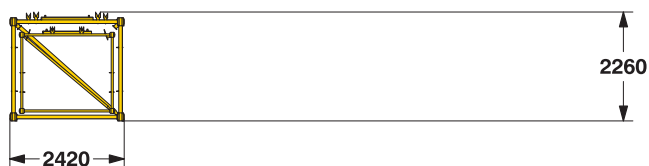

Basic machine

with A-frame, 2x 120 kN crane winches without boom foot, hoist ropes, basic counterweight and crawlers

Width	3000 mm
Weight	42500 kg
Weight of hoist rope	3.42 kg/m

Crawler

2x

Track pads	1200 mm
Width	1200 mm
Weight	19800 kg

Boom foot (No. 2320,25)

Width	2430 mm
Weight incl. winch and rope	5600 kg
Weight without winch	4000 kg

Boom section (No. 2320,23)

3 m

Width	2430 mm
Weight with HPT ¹⁾	830 kg
Weight with HPT ¹⁾ and NDL ²⁾	920 kg

Boom section (No. 2320,23)

6 m

Width	2430 mm
Weight with HPT ¹⁾	1295 kg
Weight with HPT ¹⁾ and NDL ²⁾	1455 kg

Boom section (No. 2320,23)

12 m

Width	2430 mm
Weight with HPT ¹⁾	2340 kg
Weight with HPT ¹⁾ and NDL ²⁾	2690 kg

Boom head (No. 2320,23)

Width	2430 mm
Weight with HPT ¹⁾	4300 kg

1) Pendant straps for main boom • 2) Pendant straps for jib

Boom transport option

(No. 2320.xx/1916.xx)	12/12	6/6	3/3	m
Length	12250	6250	3250	mm
Weight*	3940	2145	1475	kg

*) Including pendant straps

Transport dimensions and weights

Luffing jib (No. 1916.xx)

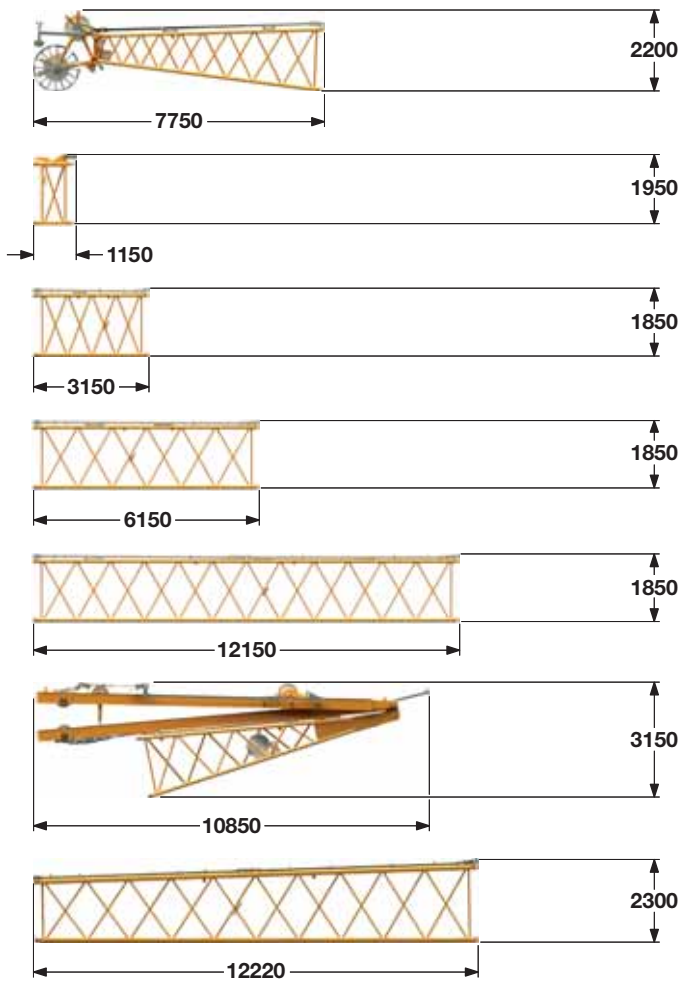

Luffing jib head (No. 1916.21)

Width	2010 mm
Weight*	1550 kg

L-boom jib section (No. 1916.22)

1 m

Width	2010 mm
Weight*	460 kg

Luffing jib section (No. 1916.18)

3 m

Width	2010 mm
Weight*	475 kg

Luffing jib section (No. 1916.18)

6 m

Width	2010 mm
Weight*	690 kg

Luffing jib section (No. 1916.18)

12 m

Width	2010 mm
Weight*	1250 kg

Luffing jib foot with A-frames (No. 1916.22)

Width	2010 mm
Weight*	6300 kg

L-boomsection tapered (No. 2320/1916.20)

12 m

Width	2430 mm
Weight*	1700 kg

*) Including pendant straps

Fixed jib (No. 1008.xx)

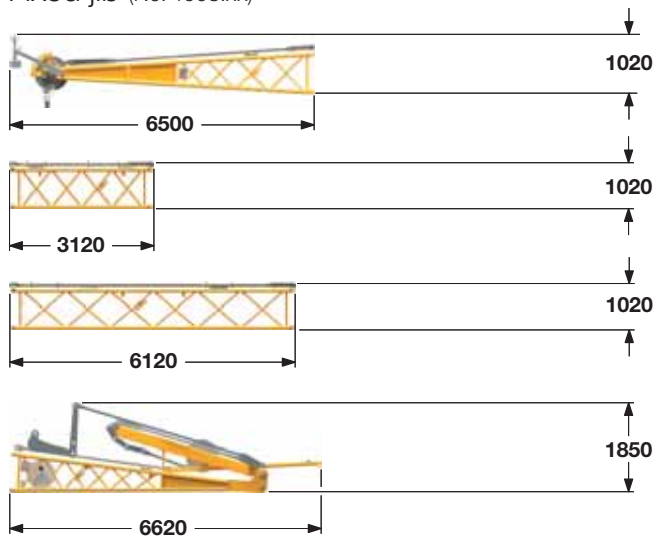

Fixed jib head (No. 1008.20)

Width	1090 mm
Weight*	920 kg

Fixed jib section (No. 1008.17)

3 m

Width	1090 mm
Weight*	300 kg

Fixed jib section (No. 1008.17)

6 m

Width	1090 mm
Weight*	455 kg

Fixed jib foot with A-frame (No. 1008.20)

Width	2200 mm
Weight*	1950 kg

*) Including pendant straps

Transport dimensions and weights

Counterweight

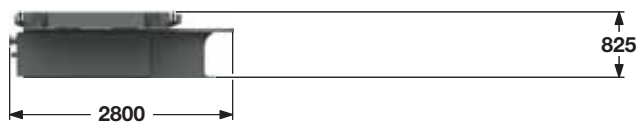
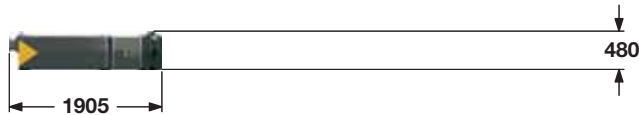

Mid fall (option)

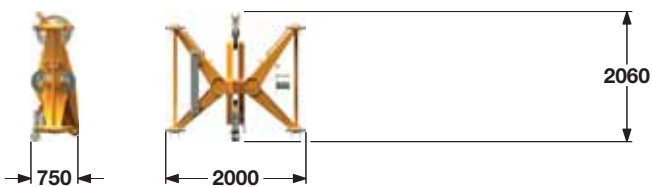

Hooks

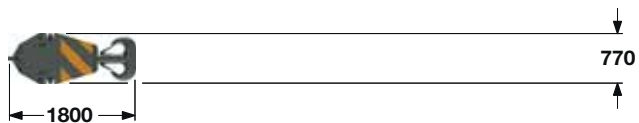
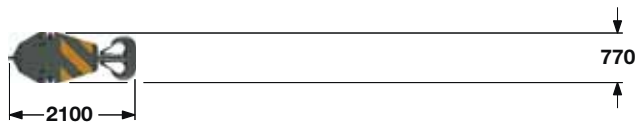
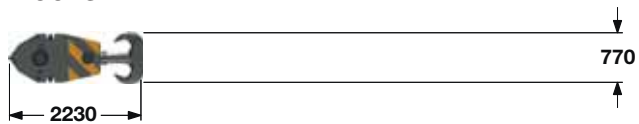

Counterweight 1x

Width	1660 mm
Weight	12000 kg

Counterweight 1x

Width	1660 mm
Weight	10000 kg

Counterweight 12x

Width	1360 mm
Weight	5000 kg

Carbody counterweight 2x

Width	3340 mm
Weight	9800 kg

Carbody counterweight 2x

Width	3340 mm
Weight	8300 kg

Mid fall section (No. 1916.xx) 0.5 m

Width	750 mm
Weight	715 kg

250 t hook block – 11 sheaves

Width	1030	1250	mm
Weight	2300	3200	kg

160 t hook block – 7 sheaves

Width	640	760	880	mm
Weight	1500	2250	3000	kg

100 t hook block – 5 sheaves

Width	540	670	770	mm
Weight	1300	1800	2300	kg

40 t hook block – 1 sheave

Width	300	400	500	mm
Weight	700	1100	1500	kg

12.5 t single hook

Width	400 mm
Weight	600 kg

Boom combinations

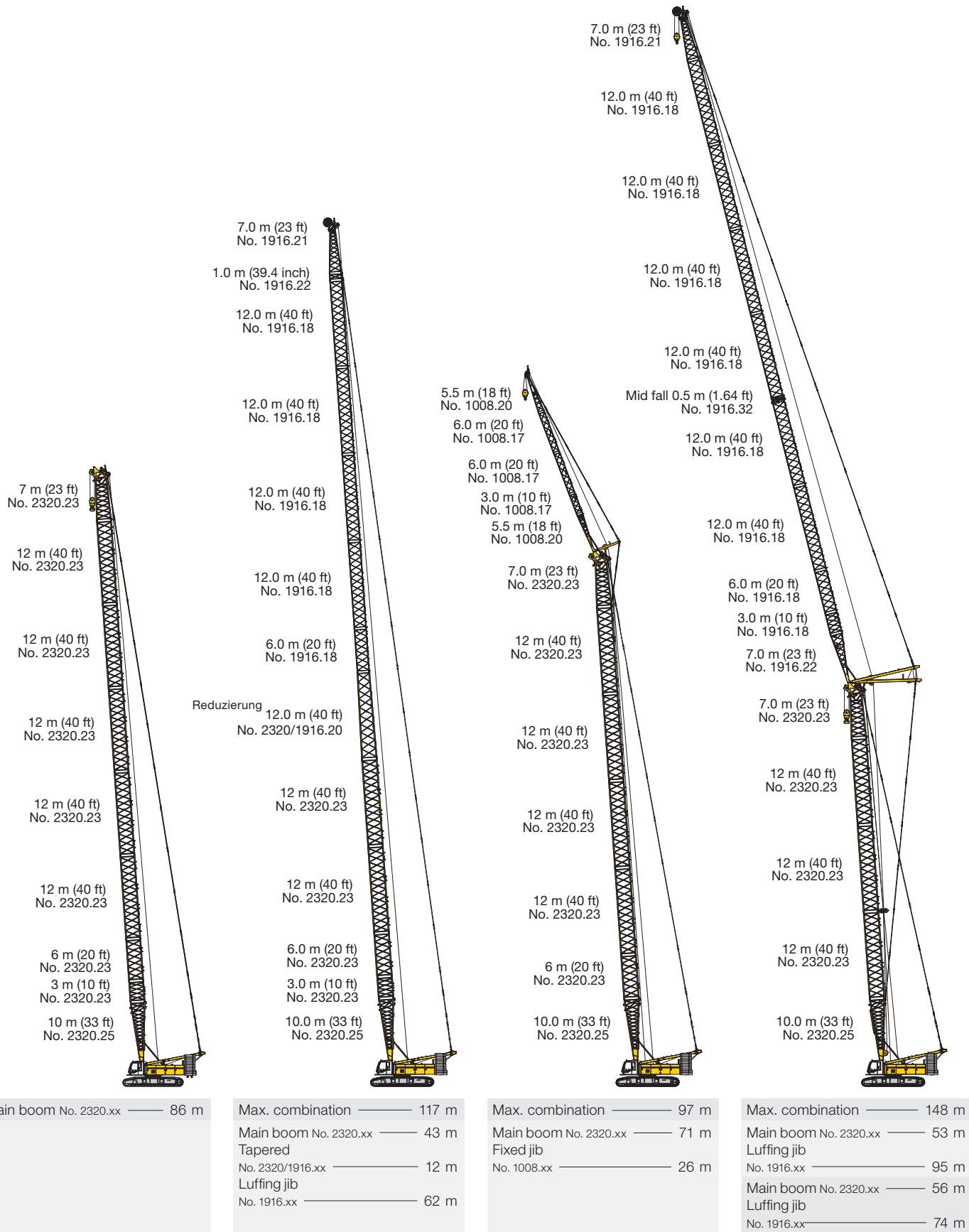

Technical description



Engine

Power rating according to ISO 9249, 230 kW (308 hp) at 1700 rpm
Engine type — Liebherr D 944 A7-04
Fuel tank — 790 l capacity with continuous level indicator and reserve warning
Engine complies with NRMM exhaust certification EPA/CARB Tier 4f and 97/68 EC Stage IV.



Hydraulic system

A double axial displacement pump supplies the open loop hydraulic system, allowing all functions to be operated simultaneously. To minimize peak pressure an automatic working pressure cut-off is integrated in the pump. All filters are electronically monitored. The use of synthetic environmentally friendly (biodegradable) oils is possible.
Working pressure — max. 350 bar
Oil tank capacity — 650 l



Luffing jib winch

Line pull — max. 105 kN
Rope diameter — 20 mm
Jib luffing — 51 sec. from 15° to 78°



Boom winch

Line pull — max. 217 kN
Rope diameter — 24 mm
Boom up — 130 sec. from 15° to 86°



Crawlers

Propulsion through axial piston motor, hydraulically released spring loaded multi-disc brake, crawler tracks, hydraulic chain tensioning device.
Track pads — 1200 mm
Drive speed — 0 – 1.6 km/h



Swing

Consists of rollerbearing with external teeth, swing drive with fixed axial piston hydraulic motor, spring loaded and hydraulically released multi-disc holding brake, planetary gearbox and pinion.
Both swing modes are possible – speed control or free swing.
A multi-disc holding brake acts automatically at zero swing motion. Swing speed from 0 – 3 rpm continuously variable.



Main winches

Line pull (7th layer) — 120 kN
Rope diameter — 26 mm
Drum diameter — 580 mm
Rope speed — 0 – 136 m/min
Rope capacity in 7 layers — 489 m
The winches are outstanding in their compact design and easy assembly. Propulsion is via a planetary gearbox in an oil bath.
Load support by the hydraulic system; additional safety factor provided by a spring loaded, multi-disc holding brake. The main winches use pressure controlled, variable flow hydraulic motors. This system features sensors that automatically adjust oil flow to provide max. winch speed depending on load.

Option – winch with free-fall system:
Clutch and braking functions on the free-fall system are provided by a compact designed, low wear and maintenance-free multi-disc brake.



Control

The heart of the hydraulic crawler cranes is the Liebherr control system which has been developed and manufactured in-house. It includes all control and monitoring functions and is designed to withstand extreme environmental conditions and heavy duty construction tasks. Complete machine operating data as well as warning signals and irregularities are clearly displayed on the high resolution monitor in the operator's cab in the required language.
The electro-hydraulic proportional control allows several movements to be performed simultaneously. This ensures that all categories of loads can be positioned with utmost precision.

Option:
GSM/GPRS telematics module



Noise emission

Noise emissions correspond with 2000/14/EC directive.
Guaranteed sound pressure level L_{PA} in the cabin — ≤ 72.9 dB(A)
Guaranteed sound power level L_{WA} — ≤ 107 dB(A)
Vibration transmitted to the hand-arm system of the machine operator — < 2.5 m/s²
Vibration transmitted to the whole body of the machine operator — < 0.5 m/s²

Self assembly system

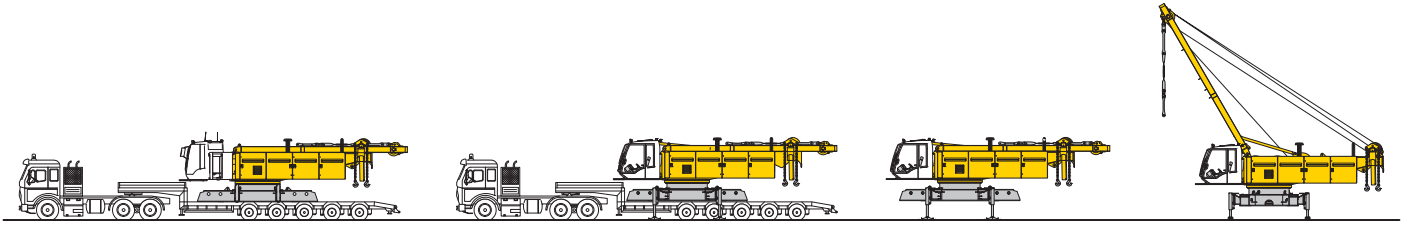

Unloading of basic machine

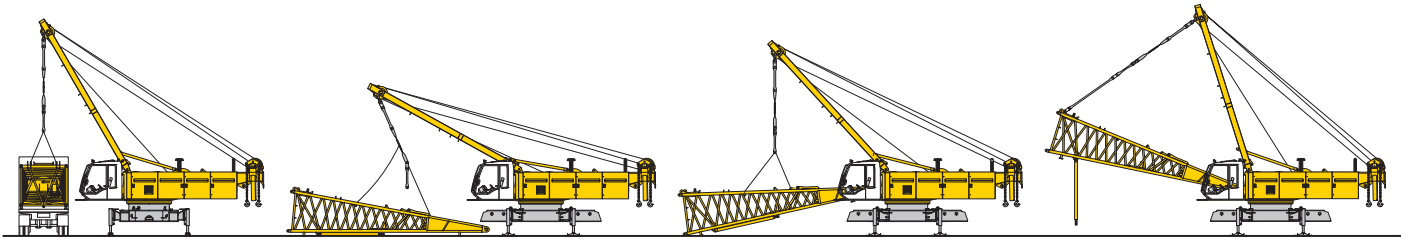

Unloading and assembly of boom foot

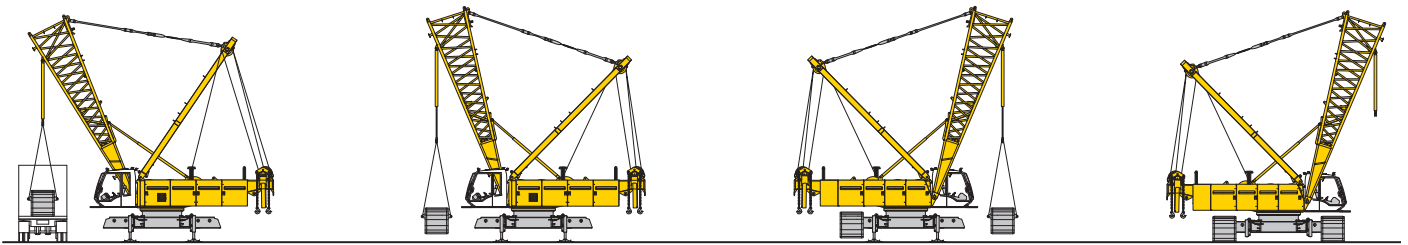

Unloading and assembly of crawlers

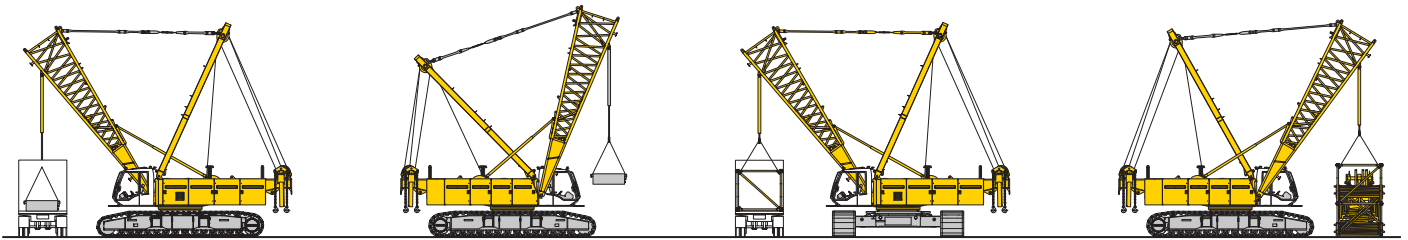

Unloading and assembly of carbody counterweight

Entladung und Zusammenbau des Auslegers

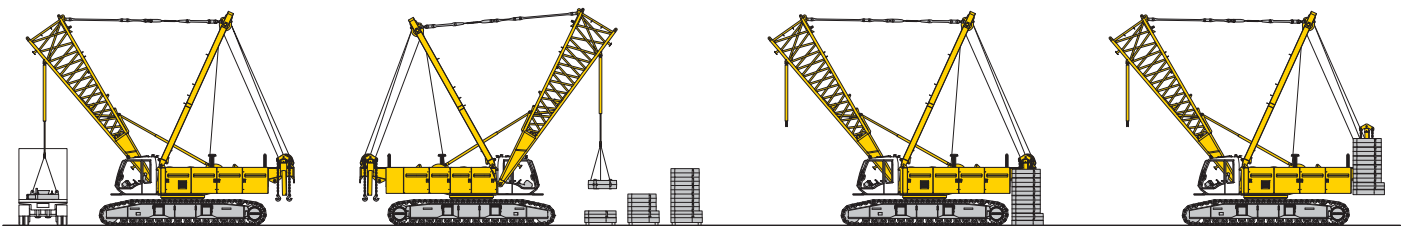

Unloading and assembly of counterweight

Erecting of main boom to working position

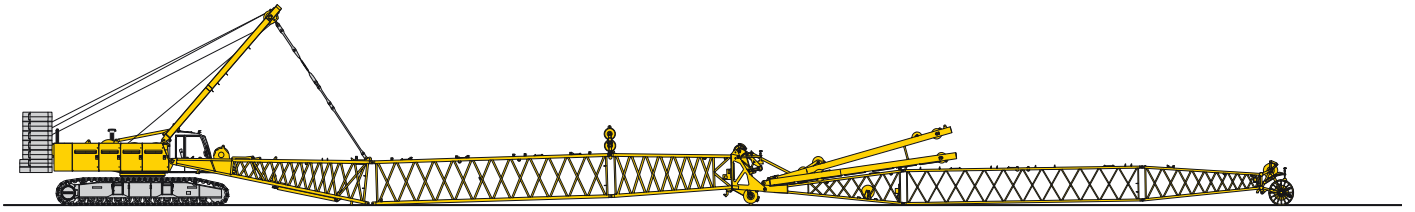

Assembly of boom

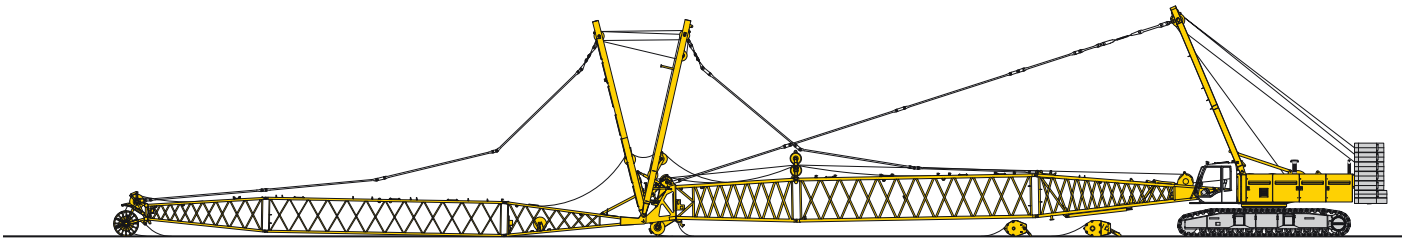

Reeving of hoist and luffing jib ropes

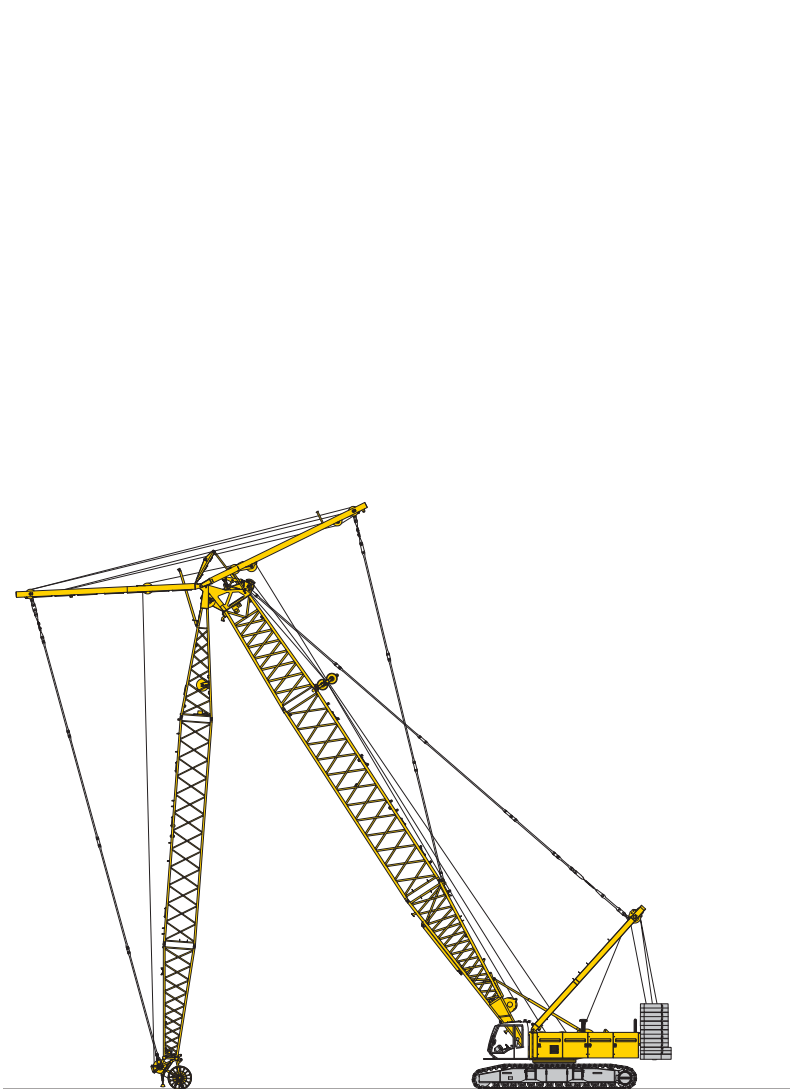

Erecting of main boom and luffing jib

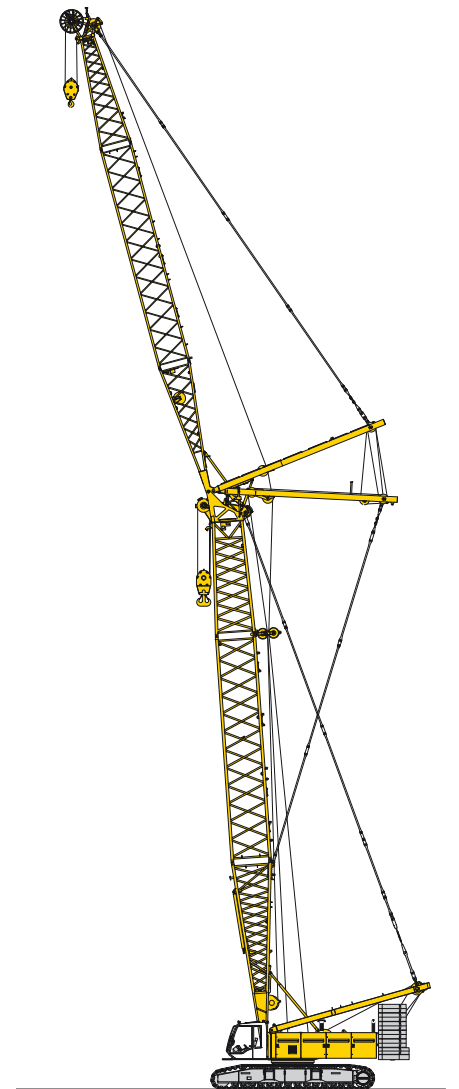

Working position

Main boom 86° - 15° (No. 2320.xx)

82.3 t counterweight and 36 t carbody counterweight

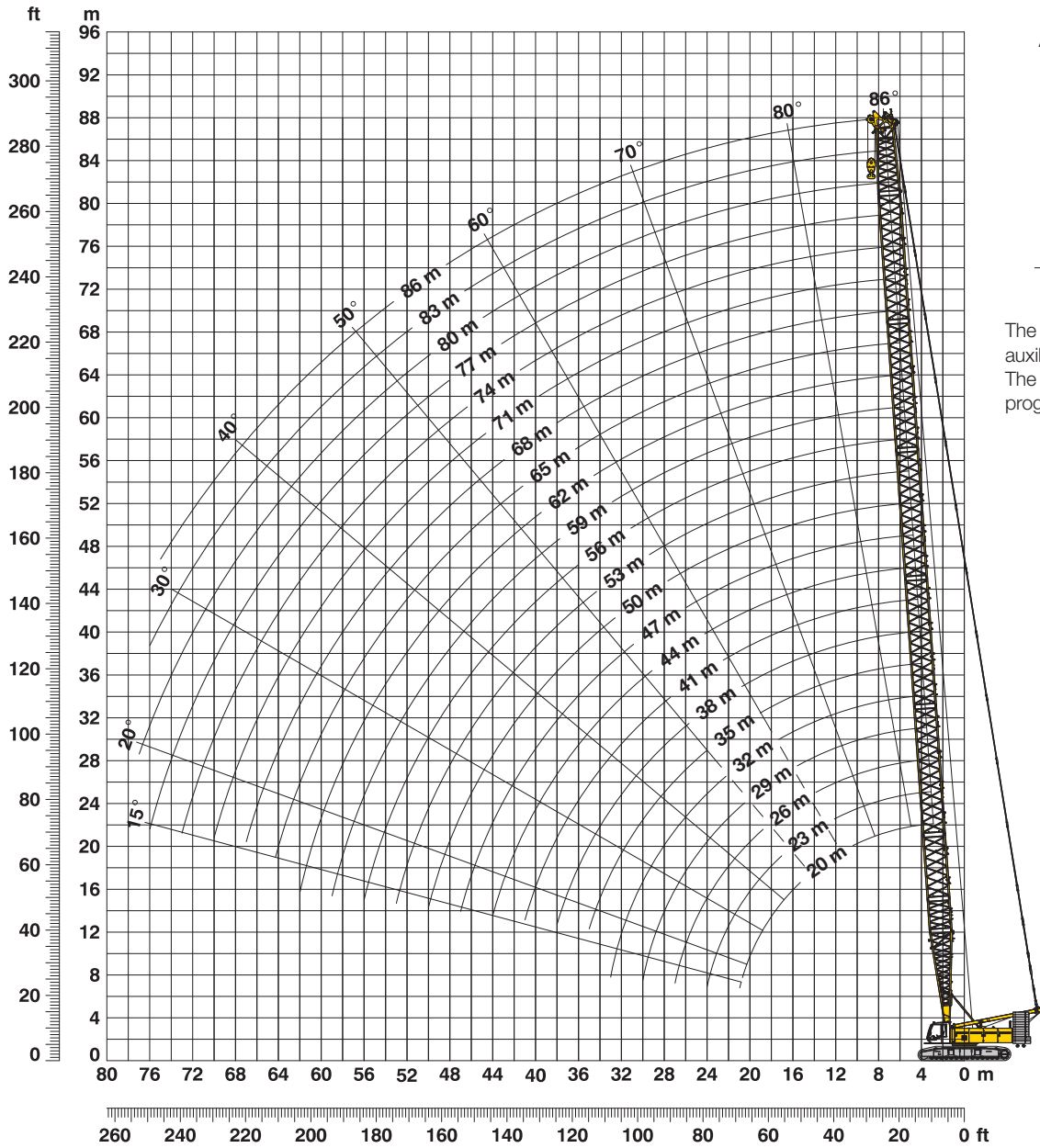

Auxiliary jib 24 t

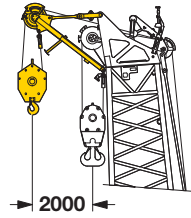

The maximum capacity of the auxiliary jib is 24 t.
The corresponding load chart is programmed in the LMI system.

Main boom configuration (Table 1 – No. 2320.xx) Configuration for boom lengths between 20 m and 86 m

Component	Length	Amount of boom extensions																										
		1	2	3	4	5	6	7	8	9	10	11	12	13	14	15	16	17	18	19	20							
Boom foot	10 m	1	1	1	1	1	1	1	1	1	1	1	1	1	1	1	1	1	1	1	1							
Boom insert	3 m	1		1		1		1		1		1		1		1		1		1								
Boom insert	6 m		1	1		1	1	1		1	1		1	1		1	1		1	1								
Boom insert	12 m				1	1	1	1		2	2	2	2		3	3	3	3		4	4	4	4		5	5	5	5
Boom head	7 m	1	1	1	1	1	1	1		1	1	1	1		1	1	1	1		1	1	1	1		1	1	1	1
Boom length (m)		20	23	26	29	32	35	38	41	44	47	50	53	56	59	62	65	68	71	74	77	80	83	86				

Lift chart for main boom (No. 2320.xx)

82.3 t counterweight and 36 t carbody counterweight

TLT 10576485 - M153553 Offiziell

Capacities in metric tonnes for boom lengths (20 m - 86 m) – with 120 kN winches

Radius (m)	Boom length in (m)												Radius (m)
	20 t	26 t	32 t	38 t	44 t	50 t	56 t	62 t	68 t	74 t	80 t	86 t	
5.8					122.1								5.8
6				143.5	122.1								6
7			149.9	136.5	117.5	101.4	86.4	72.1					7
8		139.3	132.1	124.2	112.6	96.9	83.4	71.5	59.1	49.8			8
9	128.6	122.4	115.6	109.3	103.6	93.0	80.4	68.1	57.7	49.5	41.3	34.0	9
10	113.8	108.1	102.6	97.5	92.8	88.0	77.1	65.7	56.0	48.1	40.7	33.8	10
12	87.2	87.2	83.5	79.8	76.4	73.1	70.1	61.3	52.9	45.8	39.6	32.7	12
14	70.2	70.2	70.1	67.3	64.7	62.1	59.7	57.3	50.0	43.2	37.6	31.5	14
16	58.5	58.5	58.4	57.9	55.8	53.7	51.7	49.8	47.4	41.3	35.8	30.2	16
18	49.9	49.9	49.7	49.5	48.9	47.1	45.4	43.7	42.1	38.7	34.4	29.2	18
20	43.2	43.3	43.2	42.9	42.6	41.8	40.3	38.8	37.4	36.0	32.4	28.2	20
26		30.2	30.2	29.9	29.7	29.3	28.9	28.4	27.3	26.2	25.2	24.1	26
32			22.5	22.3	22.0	21.7	21.3	20.9	20.5	19.8	19.0	18.0	32
38				17.2	17.0	16.6	16.3	15.9	15.5	15.0	14.6	13.7	38
44					13.4	13.1	12.7	12.3	12.0	11.5	11.1	10.5	44
50						10.4	10.1	9.7	9.3	8.8	8.4	7.9	50
55							8.3	7.9	7.5	7.1	6.6	6.2	55
60								6.4	6.0	5.6	5.2	4.7	60
65									4.8	4.4	4.0	3.5	65
70										3.3	2.9	2.4	70

72.3 t counterweight and 36 t carbody counterweight

TLT 10576485 - M153553 Offiziell

Capacities in metric tonnes for boom lengths (20 m - 83 m) – with 120 kN winches

Radius (m)	Auslegerlänge (m)												Radius (m)
	20 t	26 t	32 t	38 t	44 t	50 t	56 t	62 t	68 t	74 t	80 t	83 t	
4.1	250.0*												4.1
5	217.0	196.5	173.7										5
6	185.8	180.1	165.5	143.5	122.1								6
7	162.1	152.0	141.3	131.8	117.5	101.4	86.4	72.1					7
8	138.5	129.3	121.3	114.0	107.5	96.9	83.4	71.5	59.1	49.8			8
9	119.4	112.3	106.1	100.3	95.0	90.1	80.4	68.1	57.7	49.5	41.3	37.2	9
10	104.4	99.2	94.1	89.3	85.0	80.9	77.1	65.7	56.0	48.1	40.7	36.9	10
12	79.9	79.8	76.5	73.1	69.9	66.9	64.0	61.3	52.9	45.8	39.6	35.7	12
14	64.3	64.2	64.1	61.5	59.0	56.6	54.4	52.2	50.0	43.2	37.6	34.3	14
16	53.4	53.4	53.3	52.9	50.9	48.9	47.0	45.2	43.5	41.3	35.8	32.7	16
18	45.5	45.5	45.4	45.1	44.5	42.8	41.2	39.6	38.1	36.6	34.4	31.5	18
20	39.3	39.4	39.3	39.0	38.7	37.9	36.5	35.1	33.8	32.4	31.2	30.0	20
26		27.4	27.4	27.1	26.8	26.4	26.1	25.5	24.4	23.4	22.4	21.9	26
32			20.3	20.1	19.8	19.4	19.0	18.6	18.2	17.5	16.7	16.2	32
38				15.3	15.1	14.8	14.4	14.0	13.6	13.1	12.5	12.1	38
44					11.8	11.5	11.2	10.8	10.4	9.9	9.5	9.2	44
50						9.0	8.7	8.3	7.9	7.4	7.0	6.8	50
55							7.0	6.6	6.3	5.8	5.4	5.2	55
60								5.3	4.9	4.5	4.0	3.8	60
65									3.7	3.3	2.9	2.7	65
70										2.3			70

Above lift chart is for reference only. For actual lift duty please refer to lift chart in operator's cab or manual.

*) Capacities over 220 t require a special heavy duty boom head.

L-boom high reach 66 m - 117 m (No. 2320/1916.xx)

Working range 86° – 15°

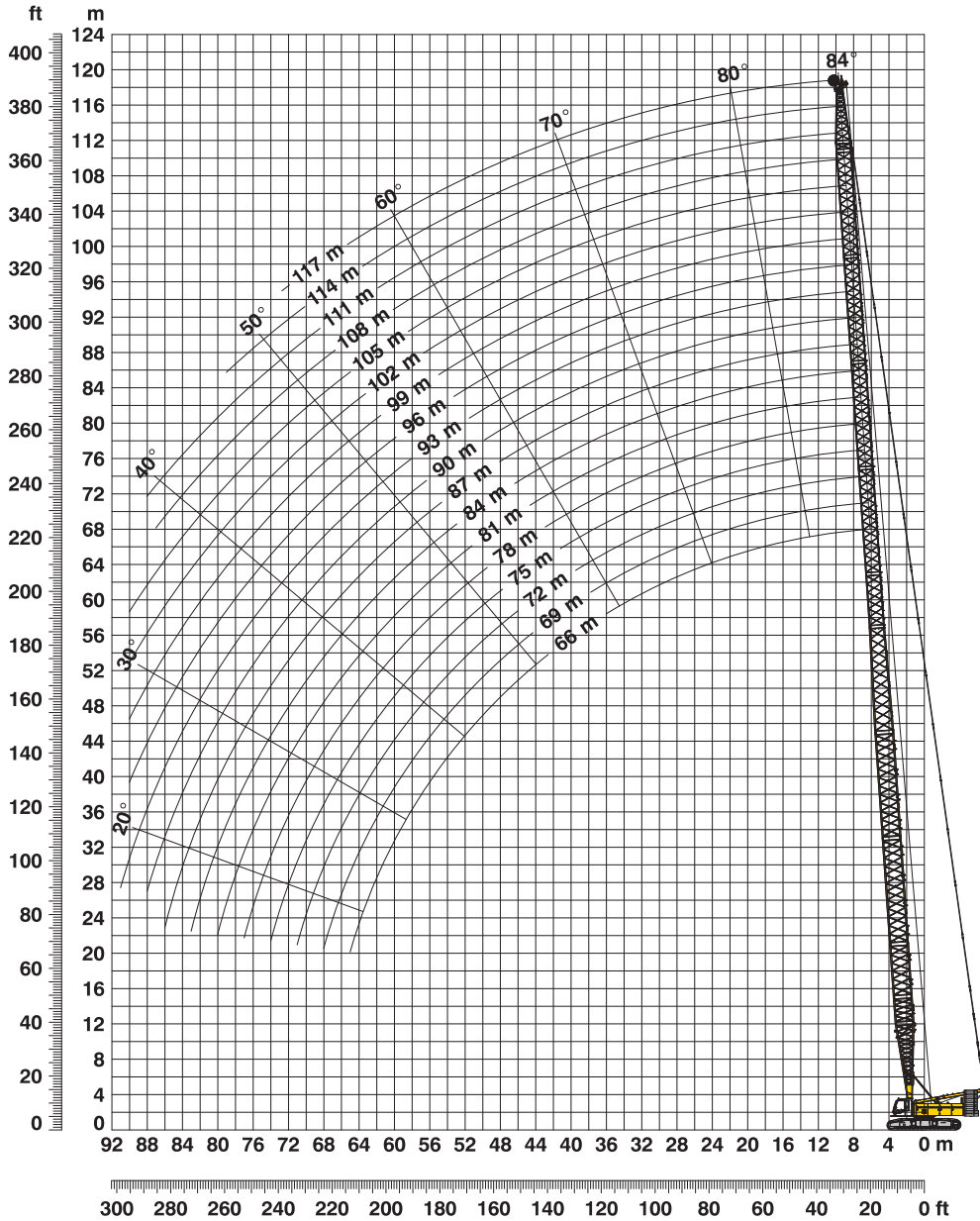

L-boom configuration with 43 m main boom (No. 2320.xx/1916.xx)

Configuration for L-boom lengths between 66 m and 117 m

	Length	Amount of boom and luffing jib extensions																	
		66	69	72	75	78	81	84	87	90	93	96	99	102	105	108	111	114	117
Boom foot	10m	1	1	1	1	1	1	1	1	1	1	1	1	1	1	1	1	1	1
Boom insert	3 m	1	1	1	1	1	1	1	1	1	1	1	1	1	1	1	1	1	1
Boom insert	6 m	1	1	1	1	1	1	1	1	1	1	1	1	1	1	1	1	1	1
Boom insert	12 m	2	2	2	2	2	2	2	2	2	2	2	2	2	2	2	2	2	2
Tapered	12 m	1	1	1	1	1	1	1	1	1	1	1	1	1	1	1	1	1	1
Luffing insert	3 m			1		1		1		1		1		1		1		1	
Luffing insert	6 m		1	1			1				1		1		1			1	
Luffing insert	12 m				1	1	1	1	2	2	2	2	3	3	3	3	4	4	4
Luffing jib head	8 m	1	1	1	1	1	1	1	1	1	1	1	1	1	1	1	1	1	1
Max. L-boom length (m)		66	69	72	75	78	81	84	87	90	93	96	99	102	105	108	111	114	117

Lift chart for L-boom high reach (No. 2320/1916.xx)

82.3 t counterweight and 36 t carbody counterweight

TLT 10576485 - M153553 Offiziell

Main boom length 43 m

Radius (m)	Boom length in (m)					
	66 t	75 t	90 t	99 t	108 t	117 t
8.9	60.9					
10	58.7	39.5				
12	51.2	37.0	23.2			
14	44.8	34.4	21.5	15.8	12.1	
16	39.5	32.0	19.9	14.6	11.4	8.8
18	35.3	30.0	18.6	13.7	10.6	8.1
20	31.8	27.7	17.3	12.7	10.0	7.6
22	29.2	25.5	16.5	11.9	9.3	7.2
24	26.6	23.8	15.5	11.3	8.7	6.7
26	24.5	22.0	14.7	10.7	8.3	6.4
28	22.9	20.4	14.1	10.2	7.9	6.1
30	21.0	19.1	13.5	9.8	7.6	5.8
32	19.5	17.9	12.9	9.5	7.3	5.5
34	18.3	16.8	12.4	9.1	7.1	5.3
36	17.2	15.8	12.1	8.7	6.8	5.1
38	16.3	15.0	11.7	8.4	6.5	4.9
40	15.5	14.2	11.2	8.2	6.3	4.7
42	14.8	13.4	10.8	7.9	6.1	4.5
44	14.0	12.7	10.5	7.6	5.9	4.4
46	13.2	12.1	10.2	7.3	5.7	4.2
48	12.5	11.5	9.8	7.1	5.4	4.1
50	11.7	11.0	9.3	6.9	5.3	3.9
55	10.0	9.7	8.4	6.3	4.9	3.6
60	8.5	8.5	7.5	5.7	4.4	3.3
65	7.3	7.3	6.5	5.2	4.0	2.9
70		6.3	5.7	4.7	3.6	2.6
80			4.2	3.7	3.0	2.0
85			3.5	3.1	2.6	
90				2.7	2.1	
95				2.2		

Main boom length 55 m

Radius (m)	Boom length in (m)					
	78 t	90 t	96 t	102 t	108 t	114 t
10.2	43.8					
12	43.0	28.3				
14	40.7	26.6	23.3	19.0	15.3	
16	37.7	24.9	21.8	17.7	14.4	12.0
18	33.2	23.5	20.7	16.6	13.4	11.2
20	30.0	22.1	19.4	15.7	12.7	10.5
22	26.8	21.1	18.4	14.7	11.9	10.0
24	24.4	19.9	17.6	14.0	11.2	9.4
26	22.5	18.9	16.8	13.4	10.7	9.0
28	20.5	18.2	16.1	12.8	10.2	8.6
30	18.8	17.1	15.6	12.3	9.8	8.2
32	17.6	15.7	14.8	11.9	9.5	7.9
34	16.2	14.5	13.7	11.5	9.2	7.6
36	15.0	13.6	12.8	11.0	8.8	7.4
38	14.0	12.7	12.0	10.6	8.5	7.1
40	13.2	11.8	11.3	10.3	8.2	6.9
42	12.5	10.9	10.5	10.1	8.0	6.7
44	11.9	10.2	9.8	9.4	7.8	6.5
46	11.3	9.7	9.1	8.7	7.3	6.3
48	10.9	9.2	8.6	8.1	6.9	6.0
50	10.5	8.7	8.1	7.6	6.5	5.7
55	9.0	7.8	7.2	6.7	5.8	5.1
60	7.7	6.9	6.4	5.9	5.1	4.6
65	6.5	5.8	5.6	5.3	4.5	4.0
70	5.4	5.0	4.7	4.5	4.0	3.5
75	4.5	4.3	4.0	3.7	3.2	3.0
80		3.6	3.3	3.1	2.6	2.3
85		2.9	2.8	2.6	2.1	
90			2.1	2.1		

Above lift chart is for reference only. For actual lift duty please refer to lift chart in operator's cab or manual.

L-boom configuration with 55 m main boom (No. 2320.xx/1916.xx)

Configuration for L-boom lengths between 78 m and 114 m

	Länge	Amount of boom and luffing jib extensions												
		78	81	84	87	90	93	96	99	102	105	108	111	114
Boom foot	10m	1	1	1	1	1	1	1	1	1	1	1	1	1
Boom insert	3m	1	1	1	1	1	1	1	1	1	1	1	1	1
Boom insert	6m	1	1	1	1	1	1	1	1	1	1	1	1	1
Boom insert	12m	3	3	3	3	3	3	3	3	3	3	3	3	3
Tapered	12m	1	1	1	1	1	1	1	1	1	1	1	1	1
Luffing insert	3m							1			1			1
Luffing insert	6m		1	1				1			1	1		
Luffing insert	12m				1	1	1	1	2	2	2	2	3	3
Luffing jib head	8m	1	1	1	1	1	1	1	1	1	1	1	1	1
Max. L-boom length (m)		78	81	84	87	90	93	96	99	102	105	108	111	114

Working range - luffing jib 78° - 15° (No. 1916.xx)

Main boom 88° – 45°

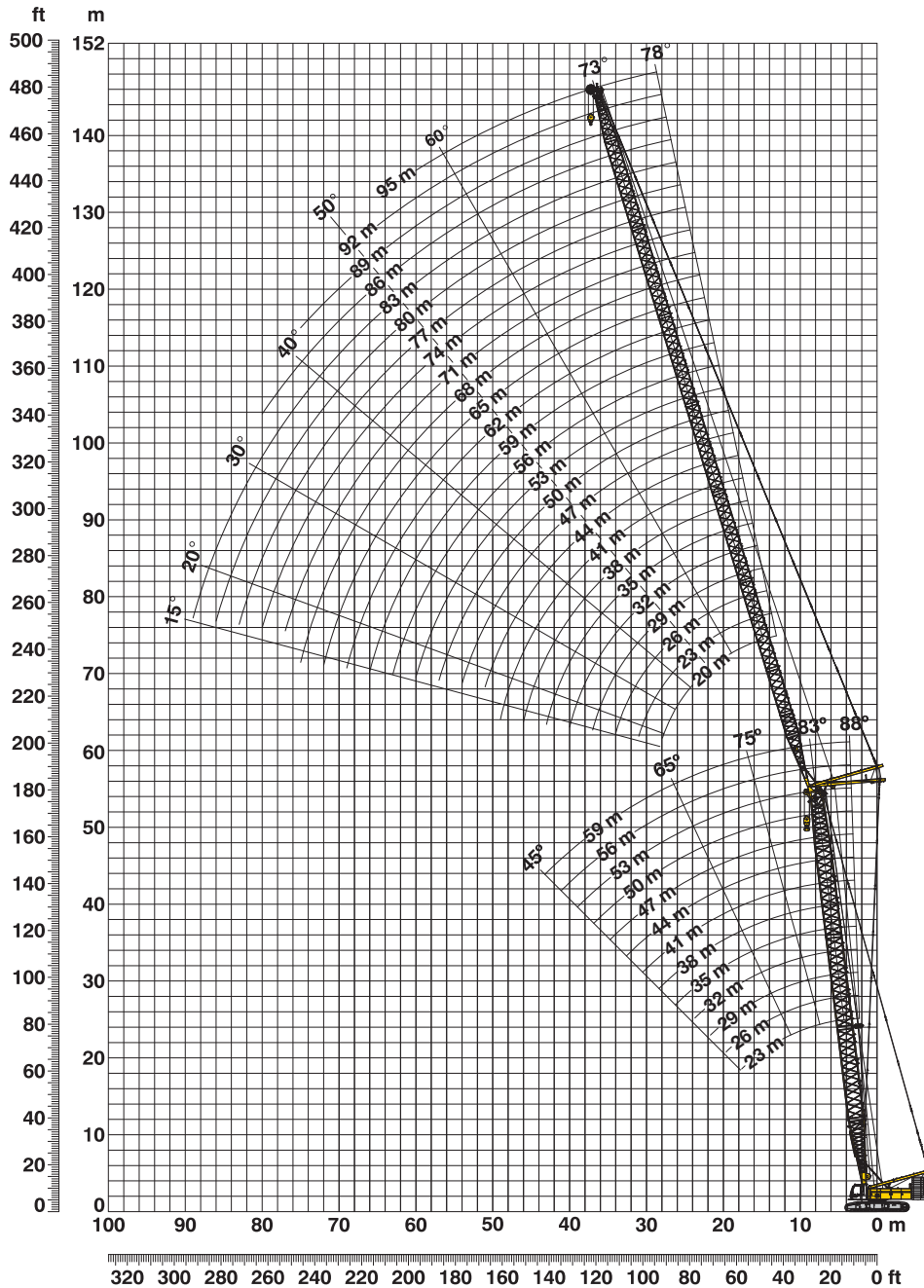

Boom configuration for main boom lengths (23 m – 59 m) (see table 1 on page 10)

Jib configuration for jib lengths (20 m – 95 m)

	Length	Amount of luffing jib extensions																																					
Luffing jib foot	7 m	1	1	1	1	1	1	1	1	1	1	1	1	1	1	1	1	1	1	1	1	1	1	1	1	1	1	1	1	1	1	1	1	1	1				
Luffing jib insert	3 m		1		1		1		1		1		1		1		1		1		1		1		1		1		1		1		1		1		1		
Luffing jib insert	6 m	1	1		1	1		1	1		1	1		1	1		1	1		1	1		1	1		1	1		1	1		1	1		1	1			
Luffing jib insert	12 m			1	1	1	1	1		2	2	2	2	3	3	3	3	4	4	4	4	5	5	5	5	6	6	6	6	7	7	7	7	8	8	8	8		
Luffing jib head	7 m	1	1	1	1	1	1	1	1	1	1	1	1	1	1	1	1	1	1	1	1	1	1	1	1	1	1	1	1	1	1	1	1	1	1	1			
Luffing jib length (m)		20	23	26	29	32	35	38	41	44	47	50	53	56	59	62	65	68	71	74	77	80	83	86	89	92	95												

Lift chart - luffing jib (No. 1916.xx)

Main boom 88°

TLT 10576485 - M153553 Offiziell

Main boom 23 m

Radius (m)	Jib length (m)							
	20	29	41	53	62	71	83	95
7.9	70.7							
10	70.7	61.8						
13	63.5	54.0	38.2					
15	53.4	48.4	35.4	25.8				
17	45.7	43.0	32.5	24.8	18.2			
19	38.4	37.1	30.1	23.7	17.6	13.0		
22	30.8	30.0	26.4	22.1	16.5	12.5	8.4	
24		26.9	24.3	20.9	15.9	12.2	8.2	5.0
28		22.2	20.4	18.8	14.8	11.6	7.9	5.0
30		20.6	18.9	17.7	14.3	11.4	7.8	4.9
38			14.5	13.4	11.8	10.3	7.2	4.7
42			12.9	11.9	10.6	9.4	6.9	4.4
50				9.6	8.4	7.9	6.0	4.0
60					6.5	5.9	4.8	3.2
70						4.4	3.6	2.4
80							2.5	

Main boom 35 m

Radius (m)	Jib length (m)							
	20	29	41	53	62	71	83	95
8.3	69.2							
11	66.0	51.6						
13	57.8	49.1	34.4					
16	45.8	42.5	31.7	22.6				
18	39.6	38.1	29.7	21.9	15.8			
19	36.8	35.3	28.8	21.6	15.6	11.5		
22	30.4	28.9	25.6	20.3	15.0	11.2	7.4	
24		26.1	23.9	19.5	14.6	11.0	7.3	4.4
32		12.1	17.5	16.0	13.4	10.4	7.1	4.3
42			13.1	12.0	10.6	9.1	6.6	4.1
50				9.8	8.6	7.9	6.0	3.8
55				8.0	7.6	6.9	5.6	3.5
60					6.8	6.0	5.0	3.2
70						4.6	3.7	2.4
75							3.2	2.0
80							2.6	

Main boom 44 m

Radius (m)	Jib length (m)							
	20	29	41	53	62	71	83	95
8.7	57.8							
11	54.9	44.0						
13	49.7	42.5	30.4					
16	40.8	37.3	28.7	19.8				
18	35.9	33.3	27.0	19.4	14.1			
20	31.5	29.3	25.2	19.0	13.9	10.3		
22	28.1	26.0	22.9	18.5	13.7	10.1	6.6	
26		21.6	19.4	16.9	13.4	9.9	6.5	3.9
32		17.6	15.7	14.4	12.5	9.7	6.5	3.9
40			12.6	11.5	10.2	8.9	6.2	3.8
44			11.2	10.3	9.2	8.0	6.1	3.8
55				8.0	6.9	6.1	4.9	3.3
60					6.2	5.3	4.4	3.0
70						4.1	3.2	2.2
75							2.7	
80							2.2	

Main boom 53 m

Radius (m)	Jib length (m)							
	20	29	41	53	62	71	83	95
9	46.6							
11	44.1	35.7						
14	39.9	33.3	24.6					
16	35.3	31.2	23.8	16.9				
18	31.6	28.8	22.8	16.5	12.4			
20	27.9	26.0	21.7	16.0	12.2	9.1		
24	12.1	21.3	18.8	15.0	11.7	8.8	5.8	
26		19.6	17.4	14.3	11.6	8.8	5.8	3.3
32		16.2	14.3	12.4	10.8	8.6	5.8	3.3
40			11.5	10.0	9.0	8.1	5.7	3.3
44			10.4	9.0	8.1	7.2	5.7	3.3
55				7.0	6.1	5.4	4.3	2.8
60					5.5	4.7	3.7	2.4
65						4.1	3.1	2.1
70						3.6	2.6	
75							2.2	

Main boom 56 m

Radius (m)	Jib length (m)							
	20	29	35	41	53	62	71	74
9.1	43.1							
11	41.3	32.6						
13	38.8	31.5	27.1					
14	37.7	30.7	26.4	22.8				
16	33.8	29.0	25.3	21.9	15.7			
18	30.5	27.2	24.0	21.0	15.3	11.9		
20	27.0	24.7	22.4	20.1	14.8	11.7	8.7	
22	24.4	22.2	21.0	18.8	14.3	11.4	8.6	7.8
24	12.1	20.4	19.0	17.9	13.8	11.1	8.4	7.7
32		15.6	14.4	13.7	11.9	10.3	8.2	7.6
38			12.4	11.6	10.1	9.1	8.0	7.4
44				10.0	8.6	7.9	6.8	6.6
55					6.7	5.9	5.1	4.9
60						5.3	4.4	4.2
70							3.4	3.2
75								2.7

Main boom 59 m

Radius (m)	Jib length (m)				
	20	29	35	41	50
9.2	39.1				
12	36.7	29.4			
13	35.7	28.8	24.8		
14	34.9	28.0	24.2	20.9	
16	31.8	26.8	23.3	20.1	16.0
18	29.0	25.5	22.3	19.3	15.4
20	25.8	23.5	21.0	18.6	14.8
22	23.4	21.2	20.0	17.6	14.3
24	12.1	19.5	18.2	16.9	13.8
32		15.0	13.8	13.1	11.7
36			12.5	11.7	10.5
38			11.9	11.1	10.0
42				10.2	9.0
44				9.7	8.6
48					7.9
50					7.6

Capacities in metric tonnes with luffing jib (No. 1916.xx), 82.3 counterweight + 36 t carbody counterweight. Above lift chart is for reference only. For actual lift duty and complete chart with all available configurations please refer to lift chart in operator's cab or manual.

Lift chart - luffing jib (No. 1916.xx)

Main boom 83°

TLT 10576485 - M153553 Offiziell

Main boom 23 m

Radius (m)	Jib length (m)							
	20	29	44	53	62	71	83	95
11.7	70.7							
15	63.6	53.8						
19	46.2	43.9	29.5					
22	37.1	36.3	26.8	22.8				
24	32.1	32.5	25.0	21.8	16.1			
28		26.2	22.1	20.4	15.4	11.9		
32		22.1	19.3	19.0	14.6	11.4	7.9	
34			18.2	17.9	14.4	11.2	7.8	4.9
42			14.4	14.4	12.2	10.1	7.1	4.6
48			10.8	11.9	10.7	9.1	6.6	4.2
50				11.3	10.2	8.9	6.4	4.2
55				9.7	9.0	8.0	6.1	3.8
65					6.6	6.5	5.0	3.2
70						5.5	4.5	2.7
75							4.0	2.3
85							2.7	

Main boom 35 m

Radius (m)	Jib length (m)							
	20	29	41	53	62	71	83	95
13.1	64.5							
16	54.6	47.5						
20	44.0	41.8	30.1					
24	34.0	33.9	26.8	20.3				
26	30.1	30.7	25.5	19.8	14.6			
28		27.8	24.2	19.4	14.4	10.9		
32		23.5	22.0	18.6	13.9	10.8	7.2	
34		21.7	20.8	18.1	13.6	10.7	7.2	
36			19.4	17.6	13.4	10.5	7.1	4.3
38			18.2	17.1	13.1	10.3	7.1	4.3
46			14.1	13.9	12.2	9.5	6.6	4.1
55				10.8	9.8	8.5	6.0	3.7
65					7.5	7.2	5.4	3.1
75						5.3	4.8	2.5
80							4.1	2.2
85							3.3	

Main boom 44 m

Radius (m)	Jib length (m)							
	20	29	41	53	62	71	83	95
14.2	51.6							
17	47.4	39.6						
22	36.9	34.6	26.3					
24	32.2	31.1	25.1	18.3				
26	29.2	28.4	23.8	18.1				
28		26.0	22.8	18.0	13.3			
30		23.8	21.4	17.7	13.3	9.8		
34		20.6	19.4	17.0	12.9	9.8	6.5	
36		12.1	18.1	16.3	12.7	9.7	6.5	
38			16.9	15.6	12.6	9.6	6.5	3.9
46			13.3	12.9	11.6	9.0	6.2	3.8
55				10.1	9.2	8.0	5.7	3.6
65					7.1	6.5	5.0	3.0
75						4.9	4.3	2.4
80							3.7	2.2
85							3.0	

Main boom 53 m

Radius (m)	Jib length (m)							
	20	29	41	53	62	71	83	95
15.3	40.3							
18	37.6	31.5						
22	33.3	28.8	22.5					
26	27.0	25.4	21.1	15.6				
28	24.7	23.8	20.4	15.5	11.7			
32		20.4	18.4	15.1	11.6	8.8		
34		19.2	17.5	14.9	11.6	8.8	5.8	
36		18.0	16.6	14.3	11.5	8.7	5.8	
38			15.6	13.6	11.4	8.7	5.8	3.3
42			13.8	12.5	10.8	8.7	5.7	3.3
48			11.8	10.6	9.9	8.2	5.7	3.3
55				9.0	8.2	7.6	5.3	3.3
60				7.5	7.2	6.6	5.1	3.0
65					6.4	5.8	4.6	2.8
75						4.4	3.6	2.2
85							2.6	

Main boom 56 m

Radius (m)	Jib length (m)							
	20	29	35	41	53	62	71	74
15.7	37.4							
19	34.6	29.0						
22	31.7	27.0	23.9	20.8				
26	26.4	24.2	22.1	19.8	14.6			
28	24.3	23.0	21.0	19.3	14.6	11.2		
32		19.7	18.9	17.7	14.2	11.2	8.3	7.6
36		17.4	16.5	16.1	13.6	11.1	8.3	7.6
40			14.7	14.2	12.5	10.9	8.3	7.6
42			13.9	13.4	12.0	10.5	8.3	7.6
46				12.1	10.8	9.8	8.1	7.5
48				11.4	10.2	9.6	7.9	7.4
55					8.6	8.0	7.3	7.0
60					7.6	7.0	6.3	6.2
65						6.3	5.5	5.4
75							4.2	4.1
80								3.5

Main boom 59 m

Radius (m)	Jib length (m)					
	20	29	35	41	50	
16	34.4					
19	32.1	26.9				
22	29.6	25.1	22.2			
24	27.5	24.2	21.3	18.8		
26	25.4	23.0	20.7	18.4	14.6	
28	23.5	22.0	19.8	18.0	14.5	
32		19.0	18.1	16.7	14.2	
36		16.8	15.9	15.4	13.4	
38		12.1	15.0	14.4	12.8	
40			14.2	13.6	12.3	
42			13.4	12.8	11.8	
44				12.2	11.2	
46				11.6	10.6	
48				11.0	10.0	
50					9.6	
55					8.6	

Capacities in metric tonnes with luffing jib (No. 1916.xx), 82.3 counterweight + 36 t carbody counterweight. Above lift chart is for reference only. For actual lift duty and complete chart with all available configurations please refer to lift chart in operator's cab or manual.

Lift chart - luffing jib (No. 1916.xx)

Main boom 75°

TLT 10576485 - M153553 Offiziell

Main boom 23 m

Radius (m)	Jib length (m)							
	20	29	41	53	62	71	83	95
18	50.5							
22	39.8	39.2						
28	12.1	29.3	26.7					
32		24.9	23.8	20.3				
36		21.5	21.1	19.5	14.5			
40			18.3	17.7	13.9	10.8		
44			16.3	15.8	13.2	10.4	7.0	
48			14.3	14.1	12.6	10.0	6.8	
50				13.3	12.1	9.8	6.7	4.3
55				11.7	10.7	9.3	6.4	4.0
60				9.6	9.6	8.3	6.1	3.7
65					8.3	7.5	5.7	3.4
70						6.7	5.1	3.1
75						5.9	4.7	2.8
80							4.3	2.5
85							3.8	2.2

Main boom 35 m

Radius (m)	Jib length (m)							
	20	29	41	53	62	71	83	95
22	36.9							
26	30.9	29.8						
30	25.9	25.6	24.2					
36		20.4	19.9	18.6				
40		12.1	17.4	16.6	13.4			
44			15.4	14.8	13.0	10.1		
48			13.7	13.2	12.6	9.8	6.6	
50			13.0	12.5	12.1	9.6	6.5	
55				11.0	10.6	9.3	6.2	3.9
60				9.7	9.3	8.8	6.0	3.6
65					8.2	7.7	5.8	3.4
70					7.3	6.8	5.6	3.1
75						6.0	5.4	2.9
80						5.3	4.8	2.6
85							4.2	2.4
90							3.7	2.2

Main boom 44 m

Radius (m)	Jib length (m)							
	20	29	41	53	62	71	83	95
24	31.0							
28	26.6	25.2						
32	22.9	22.0	20.6					
38		18.2	17.1	15.9				
42		16.0	15.4	14.2	12.7			
46			13.8	12.8	12.0	9.4		
48			13.0	12.1	11.4	9.3		
50			12.3	11.6	10.9	9.2	6.2	
55				10.3	9.6	8.8	6.0	3.7
60				9.0	8.6	7.8	5.8	3.5
65				8.0	7.6	6.9	5.6	3.3
70					6.8	6.1	5.2	3.1
75						5.5	4.6	2.9
80						4.9	4.0	2.6
85							3.5	2.4
90							3.1	2.2

Main boom 53 m

Radius (m)	Jib length (m)							
	20	29	41	53	62	71	83	95
25.2	26.7							
30	22.5	21.3						
34	19.8	18.7	17.3					
36	12.1	17.6	16.3					
40		15.8	14.6	13.4				
44		14.2	13.1	12.0	11.2			
48			11.9	10.8	10.1	8.7		
50			11.3	10.3	9.6	8.6		
55			10.1	9.1	8.4	7.6	5.6	
60				8.1	7.5	6.7	5.5	3.1
65				7.3	6.6	5.9	4.9	3.1
70					5.9	5.2	4.3	2.9
75					5.3	4.6	3.7	2.7
80						4.0	3.2	2.3
85						3.5	2.7	
90							2.3	

Main boom 56 m

Radius (m)	Jib length (m)							
	20	29	35	41	53	62	71	74
26	25.0							
30	21.7	20.5						
34	19.1	18.0	17.3					
36	18.0	17.0	16.3	15.7				
40		15.2	14.5	14.0	12.8			
44		13.7	13.1	12.6	11.5	10.7		
46			12.4	11.9	10.9	10.1		
48			11.9	11.4	10.3	9.6	8.3	
50			11.3	10.8	9.8	9.1	8.2	7.5
55				9.7	8.7	8.0	7.2	7.0
60					7.7	7.1	6.3	6.1
65					6.9	6.3	5.5	5.4
70						5.6	4.8	4.7
75						5.0	4.2	4.1
80							3.7	3.6
85							3.3	3.1

Main boom 59 m

Radius (m)	Jib length (m)					
	20	29	35	41	50	
26.7	23.4					
28	22.4					
30	20.9					
32	19.6	18.5				
34	18.4	17.3	16.6			
36	17.3	16.3	15.6	15.0		
38		15.4	14.8	14.2		
40		14.6	14.0	13.4	12.6	
42		13.8	13.2	12.7	11.9	
44		13.1	12.5	12.0	11.3	
46		12.1	11.9	11.4	10.7	
48			11.4	10.9	10.2	
50			10.9	10.4	9.7	
55				9.2	8.6	
60					7.6	
65					6.8	

Capacities in metric tonnes with luffing jib (No. 1916.xx), 82.3 counterweight + 36 t carbody counterweight. Above lift chart is for reference only. For actual lift duty and complete chart with all available configurations please refer to lift chart in operator's cab or manual.

Lift chart - luffing jib (No. 1916.xx)

Main boom 65°

TLT 10576485 - M153553 Offiziell

Main boom 23 m

Radius (m)	Jib length (m)							
	20 t	29 t	41 t	53 t	62 t	71 t	83 t	95 t
26	30.7							
30	25.7	25.4						
32	12.1	23.4						
38		18.9	18.4					
40		17.7	17.3					
44			15.3	14.7				
48			13.6	13.1				
50			12.9	12.4	12.0			
55				10.8	10.4	9.6		
60				9.5	9.2	8.7		
65					8.1	7.6	6.0	
70					7.2	6.7	5.7	3.2
75						6.0	5.4	3.0
80						5.3	4.7	2.7
85							4.1	2.4
90							3.6	2.2

Main boom 35 m

Radius (m)	Jib length (m)							
	20 t	29 t	41 t	53 t	62 t	71 t	83 t	95 t
29.2	24.0							
34	20.2							
36	18.8	18.4						
40		16.1						
42		15.1	14.5					
44		14.2	13.6					
50			11.5	10.9				
55			10.1	9.5	9.1			
60				8.3	7.9	7.3		
65				7.4	7.0	6.4		
70					6.1	5.6	4.8	
75					5.4	4.9	4.2	3.0
80						4.3	3.6	2.8
85						3.8	3.1	2.3
90							2.7	
95							2.3	

Main boom 44 m

Radius (m)	Jib length (m)						
	20 t	29 t	41 t	53 t	62 t	71 t	83 t
33	19.2						
38	16.1						
40	15.0	14.6					
46		12.1	11.5				
48		11.5	10.9				
55			9.0	8.2			
60			7.9	7.3	6.6		
65				6.4	5.8	5.1	
70				5.6	5.2	4.4	3.5
75					4.6	3.8	3.0
80					4.0	3.3	2.5
85						2.9	2.0
90						2.5	

Main boom 53 m

Radius (m)	Jib length (m)					
	20 t	29 t	41 t	53 t	62 t	71 t
36.8	14.7					
40	13.4					
42	12.7	11.8				
44	11.9	11.2				
48		10.1				
50		9.6	8.5			
55			7.5			
60			6.7	5.7		
65			5.9	5.0	4.4	
70				4.4	3.8	3.0
75				3.9	3.3	2.5
80					2.8	2.1
85					2.4	

Main boom 56 m

Radius (m)	Jib length (m)							
	20 t	29 t	35 t	41 t	53 t	62 t	71 t	74 t
38.1	13.3							
44	11.3	10.4						
46	10.7	9.9						
48		9.4	8.8					
55			7.4	6.9				
60			6.6	6.1	5.2			
65				5.4	4.5	3.9		
70					3.9	3.3	2.5	2.4
75					3.4	2.8	2.1	
80						2.4		
85						2.0		

Main boom 59 m

Radius (m)	Jib length (m)				
	20 t	29 t	35 t	41 t	50 t
39.4	12.0				
42	11.2				
44	10.6				
46	10.0	9.2			
48		8.7	8.1		
50		8.3	7.7		
55		7.3	6.8	6.3	
60			6.0	5.6	4.9
65				4.9	4.3
70					3.7
75					3.3

Capacities in metric tonnes with luffing jib (No. 1916.xx), 82.3 counterweight + 36 t carbody counterweight. Above lift chart is for reference only. For actual lift duty and complete chart with all available configurations please refer to lift chart in operator's cab or manual.

Lift chart - luffing jib (No. 1916.xx)

Main boom 45°

TLT 10576485 - M153553 Offiziell

Main boom 23 m

Radius (m)	Jib length (m)						
	20 t	29 t	41 t	53 t	62 t	71 t	83 t
35.4	18.9						
38	17.2						
44		13.9					
46		13.1					
55			9.9				
65				7.2			
70				6.3	5.9		
75					5.2		
80						4.1	
85						3.6	
90							2.5
95							2.1

Main boom 35 m

Radius (m)	Jib length (m)					
	20 t	29 t	41 t	53 t	62 t	
43.8	11.9					
46	11.2					
55		8.3				
65			5.9			
75				4.0		
80					3.0	
85					2.6	

Main boom 44 m

Radius (m)	Jib length (m)			
	20 t	29 t	41 t	53 t
50.2	8.0			
60		5.7		
70			3.7	
80				2.1

Main boom 53 m

Radius (m)	Jib length (m)	
	20 t	29 t
56.6	4.9	
65		3.3

Main boom 56 m

Radius (m)	Jib length (m)	
	20 t	29 t
58.7	3.9	
60	3.8	
70		2.1

Main boom 59 m

Radius (m)	Jib length (m)	
	20 t	
60.8	2.9	

Capacities in metric tonnes with luffing jib (No. 1916.xx), 82.3 counterweight + 36 t carbody counterweight. Above lift chart is for reference only. For actual lift duty and complete chart with all available configurations please refer to lift chart in operator's cab or manual.

Working range - fixed jib 15° and 30° (No. 1008.xx)

Main boom 88° – 30°

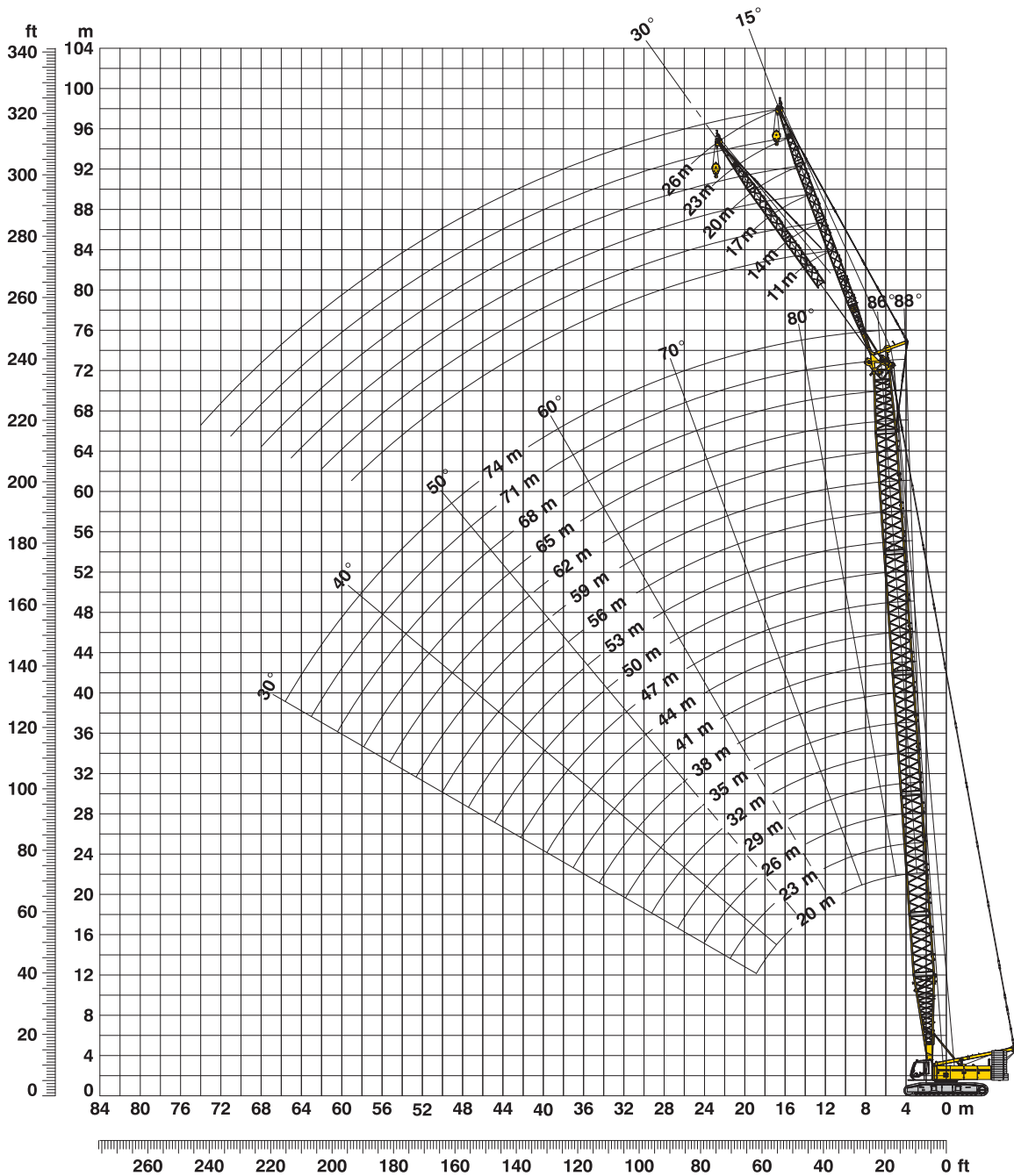

Boom configuration for boom lengths (20 m – 74 m) – see table 1 on Seite 10

Fixed jib configuration for fixed jib lengths (11 m – 26 m)

	Length	Amount of fixed jib extensions					
Fixed jib foot	5.5 m	1	1	1	1	1	1
Fixed jib insert	3.0 m		1		1		1
Fixed jib insert	6.0 m			1	1	2	2
Fixed jib head	5.5 m	1	1	1	1	1	1
Fixed jib length (m)		11	14	17	20	23	26

Lift chart - fixed jib (No. 1008.xx)

Offset 15°

TLT 10576485 - M153553 Offiziell

Main boom 20 m

Radius (m)	Fixed jib length in (m)			
	11	14	20	26
9	35.9	35.5		
11	35.9	34.0	28.9	
12	35.9	33.2	27.7	19.8
14	35.9	31.5	25.5	18.3
16	35.1	29.9	23.9	17.1
20	32.8	26.5	20.0	15.1
24	27.5	23.2	17.0	13.4
28	24.0	20.7	14.8	11.7
30	23.0	19.5	13.8	11.1
32		18.4	13.0	10.5
38			11.3	9.0
44				7.9

Main boom 29 m

Radius (m)	Fixed jib length in (m)			
	11	14	20	26
8	35.9	35.9		
10	35.9	35.2	30.2	
12	35.9	34.2	28.5	19.7
16	35.9	32.0	25.0	17.3
20	34.7	29.9	21.9	15.4
28	27.6	24.6	17.1	13.0
32	23.0	21.8	15.3	11.6
36	19.3	19.7	13.7	10.6
38	17.8	18.2	13.2	10.1
40		16.8	12.7	9.7
46			11.4	8.7
50				8.1

Main boom 38 m

Radius (m)	Fixed jib length in (m)			
	11	14	20	26
6.3	35.9			
8	35.9	35.8		
10	35.9	35.2	29.4	
13	35.9	33.6	26.8	18.9
16	35.9	32.3	24.7	17.3
20	35.9	30.3	22.6	15.6
28	27.0	26.2	18.6	13.5
36	18.7	19.0	15.1	11.5
46	12.5	12.8	12.5	9.5
48		11.9	12.1	9.2
55			9.7	8.4
60				7.9

Main boom 47 m

Radius (m)	Fixed jib length in (m)			
	11	14	20	26
6.6	35.9			
8	35.9	35.8		
11	35.9	34.5	28.3	
13	35.9	33.7	26.9	18.5
16	35.9	32.6	25.1	17.1
20	34.8	31.1	22.9	15.7
28	26.4	26.8	19.8	13.7
36	18.1	18.4	16.8	12.3
50	10.2	10.5	11.0	9.7
55		8.7	9.1	9.0
60			7.6	8.0
65				6.7

Main boom 56 m

Radius (m)	Fixed jib length in (m)			
	11	14	20	26
6.9	35.9			
9	35.9	34.5		
11	35.9	33.7	26.6	
13	35.9	32.8	25.5	17.8
20	34.3	29.9	22.0	15.5
28	25.4	25.6	19.5	13.7
36	17.4	17.8	17.3	12.7
44	12.3	12.6	13.1	11.2
55	7.8	8.0	8.5	8.9
60	6.2	6.5	7.0	7.4
70			4.5	4.9
75				3.9

Main boom 62 m

Radius (m)	Fixed jib length in (m)			
	11	14	20	26
7.1	35.9			
9	35.9	33.9		
11	35.9	33.2	25.5	
13	35.9	32.4	24.7	17.3
20	32.7	28.9	21.6	15.2
28	24.3	24.5	19.3	13.6
36	17.0	17.3	17.7	12.6
44	11.8	12.1	12.7	11.5
55	7.3	7.6	8.1	8.5
65	4.5	4.8	5.2	5.6
75			3.1	3.5
80				2.6

Main boom 68 m

Radius (m)	Fixed jib length in (m)			
	11	14	20	26
7.3	35.9			
9	35.9	32.8		
11	35.8	32.3	24.3	
14	34.9	30.9	23.2	16.7
20	31.1	27.8	20.9	14.9
28	23.4	23.5	18.8	13.4
36	16.3	16.5	16.9	12.5
44	11.4	11.7	12.3	11.7
55	6.9	7.1	7.6	8.1
70	3.0	3.2	3.7	4.1
75		2.3	2.7	3.1
80				2.2

Main boom 71 m

Radius (m)	Fixed jib length in (m)			
	11	14	20	26
7.4	35.8			
9	35.2	32.2		
11	33.9	31.0	24.0	
14	32.6	29.4	22.8	16.3
16	31.9	28.7	21.9	15.8
20	29.3	26.9	20.7	14.6
28	22.9	23.1	18.7	13.3
36	15.9	16.1	16.5	12.4
44	11.2	11.5	11.9	11.6
55	6.6	6.9	7.4	7.9
65	3.9	4.1	4.6	5.0
75		2.0	2.5	2.9

Main boom 74 m

Radius (m)	Fixed jib length in (m)		
	11	14	17
7.6	35.1		
9	34.3	31.1	
10	32.8	30.8	27.8
12	31.2	28.3	26.7
16	30.1	26.9	24.4
20	27.8	25.5	23.4
28	22.4	22.3	21.1
36	15.5	15.7	15.9
44	10.9	11.1	11.3
55	6.4	6.6	6.9
70	2.5	2.8	3.0
75			2.0

Capacities in metric tonnes with fixed jib (No. 1008.xx), 82.3 counterweight + 36 t carbody counterweight. Above lift chart is for reference only. For actual lift duty and complete chart with all available configurations please refer to lift chart in operator's cab or manual.

Lift chart - fixed jib (No. 1008.xx)

Offset 30°

TLT 10576485 - M153553 Offiziell

Main boom 20 m

Radius (m)	Fixed jib length in (m)			
	11	14	20	26
11	34.8			
12	32.7	26.9		
14	29.8	24.7	17.5	
18	25.1	21.6	15.1	12.1
20	23.4	20.1	14.0	11.3
24	21.5	17.6	12.3	9.8
26	20.3	16.7	11.7	9.2
28	19.6	15.9	11.2	8.7
30	19.0	15.2	10.8	8.3
34		14.5	9.8	7.6
40			9.1	6.8
46				6.4

Main boom 29 m

Radius (m)	Fixed jib length in (m)			
	11	14	20	26
10	35.9			
11	35.2	28.9		
15	30.8	25.8	17.8	
18	27.6	24.0	16.0	12.0
24	23.3	20.1	13.4	10.2
28	22.0	18.2	12.2	9.2
32	20.2	16.7	11.2	8.5
36	19.2	15.7	10.6	7.9
38	17.9	15.3	10.2	7.6
40		15.0	9.9	7.4
46			9.5	6.8
50				6.6

Main boom 38 m

Radius (m)	Fixed jib length in (m)			
	11	14	20	26
8.9	35.9			
11	35.7	28.3		
15	32.3	25.9	17.5	
19	28.7	23.5	15.6	12.0
20	27.8	23.4	15.2	11.7
28	23.2	19.1	12.6	9.6
36	19.0	16.6	11.1	8.4
44	13.7	14.0	9.9	7.4
46	12.6	13.0	9.7	7.2
48		12.0	9.5	7.1
55			9.2	6.7
60				6.5

Main boom 47 m

Radius (m)	Fixed jib length in (m)			
	11	14	20	26
9.3	35.9			
12	35.5	28.8		
15	33.6	27.2	17.5	
19	30.1	24.6	16.1	12.0
20	29.5	24.0	15.8	11.7
28	24.8	21.0	13.4	9.9
36	18.5	18.2	11.8	8.7
44	13.2	13.5	10.8	7.8
50	10.4	10.7	10.0	7.3
55		8.8	9.4	6.9
60			7.7	6.7
65				6.6

Main boom 56 m

Radius (m)	Fixed jib length in (m)			
	11	14	20	26
9.6	35.9			
12	35.3	28.0		
16	32.6	25.7	17.2	
19	30.4	24.2	16.1	11.8
28	25.9	20.8	13.6	10.1
36	17.9	18.0	12.1	9.0
44	12.6	13.0	11.0	8.1
55	7.9	8.2	8.9	7.2
60	6.3	6.6	7.2	6.9
65		5.3	5.8	6.4
70			4.6	5.1
75				4.0

Main boom 62 m

Radius (m)	Fixed jib length in (m)			
	11	14	20	26
9.8	34.1			
12	33.1	26.7		
16	30.6	24.8	17.0	
19	28.9	23.8	16.2	11.7
28	25.1	20.6	13.7	10.2
36	17.5	18.0	12.3	9.1
44	12.2	12.6	11.3	8.3
55	7.5	7.8	8.5	7.4
65	4.6	4.9	5.5	6.0
70		3.7	4.3	4.8
75			3.2	3.7
80				2.7

Main boom 68 m

Radius (m)	Fixed jib length in (m)			
	11	14	20	26
10	31.8			
12	31.1	25.6		
16	28.8	24.1	17.0	
20	26.9	22.9	16.0	11.7
28	23.8	20.0	14.0	10.3
36	16.9	17.3	12.6	9.3
44	11.8	12.2	11.5	8.4
55	7.1	7.4	8.1	7.6
65	4.2	4.5	5.1	5.7
70	3.1	3.4	3.9	4.4
75		2.3	2.9	3.4
80				2.4

Main boom 71 m

Radius (m)	Fixed jib length in (m)			
	11	14	20	26
10.1	30.1			
12	29.0	25.3		
16	26.7	24.0	17.3	
20	25.4	22.5	16.4	11.6
28	22.6	19.9	14.3	10.4
36	16.5	16.9	12.9	9.3
44	11.6	12.0	11.7	8.5
55	6.9	7.2	7.9	7.6
65	4.0	4.3	4.9	5.5
70	2.9	3.2	3.7	4.3
75		2.1	2.7	3.2
80				2.2

Main boom 74 m

Radius (m)	Fixed jib length in (m)		
	11	14	17
10.2	28.8		
13	26.0	24.1	
14	25.1	23.7	20.4
16	24.9	22.8	20.6
20	24.2	21.4	19.1
28	21.7	19.1	16.8
36	16.1	16.5	15.1
44	11.3	11.7	12.0
55	6.7	7.0	7.4
65	3.8	4.1	4.4
70	2.7	2.9	3.3
75			2.2

Capacities in metric tonnes with fixed jib (No. 1008.xx), 82.3 counterweight + 36 t carbody counterweight. Above lift chart is for reference only. For actual lift duty and complete chart with all available configurations please refer to lift chart in operator's cab or manual.

Notice

